

Accessibility Evaluation

Monroe County Polling Location



Summit Elementary
1450 W Countryside Ln
Bloomington, IN 47403

Inspection Date: 03/24/2026

Inspectors: Michael Shermis, Annabelle Vosmeier

Prepared By
Monroe County
(916) 473 - 9444

Report Date: 04/06/2026

Table of Contents

Findings	3
Exterior	3
Path of Travel	3

Exterior: Path of Travel

Finding: 1

The change in level where the gutter meets the curb ramp is greater than 1/4 inch.

1/4 inch is the maximum vertical rise. Changes in level between 1/4 inch and 1/2 inch must be beveled at 1:2 or less. Changes in level greater than 1/2 inch must be by way of a ramp.

2010 ADAS Section 303.3

Changes in level between 1/4 inch (6.4 mm) high minimum and 1/2 inch (13 mm) high maximum shall be beveled with a slope not steeper than 1:2.

Citation:

2010 ADAS Section: 303.3

Recommendation:

Consider adding a temporary ramp.

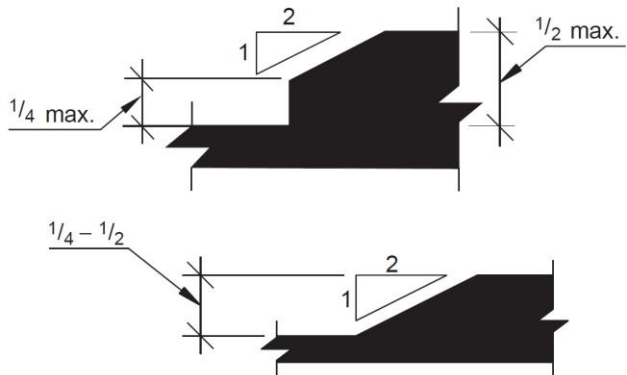

Exterior: Path of Travel

Finding: 2

The access aisle is not located on an accessible route of travel to the accessible building entrance.

Accessible parking spaces serving a particular building shall be located on the shortest accessible route of travel from parking to an accessible entrance. In buildings with multiple accessible entrances with adjacent parking, accessible parking spaces shall be dispersed and located closest to the accessible entrances.

2010 ADAS Section 208.3.1

Parking spaces complying with 502 that serve a particular building or facility shall be located on the shortest accessible route from parking to an entrance complying with 206.4. Where parking serves more than one accessible entrance, parking spaces complying with 502 shall be dispersed and located on the shortest accessible route to the accessible entrances. In parking facilities that do not serve a particular building or facility, parking spaces complying with 502 shall be located on the shortest accessible route to an accessible pedestrian entrance of the parking facility.

2010 ADAS Section 502.3

Access aisles serving parking spaces shall comply with 502.3. Access aisles shall adjoin an accessible route. Two parking spaces shall be permitted to share a common access aisle.

Citation:

2010 ADAS Section: 208.3.1, 502.3

Recommendation:

Add cones to create a path of travel between the access aisle and the curb ramp.

